



INNOVATION IN GREEN LIVING

alpineupvc.com



EUROPEAN STANDARD
UPVC PROFILES / WINDOWS & DOORS

ALPINE

Alpine Industries were established in the year 2006 and is managed by a team of Engineers who are passionate towards building and manufacturing environment - sustainable products. Key offerings include heat reduction, sound insulation, durability, absolutely maintenance-free, eco-friendly and termite resistant products. European Standard uPVC Profiles and Assisting Profiles are extruded indigenously in our state-of-the-art production facility aided by the most advanced machineries and infrastructure.

QUALITY CONTROL

Premium quality additives from the world's leading brands are used by Alpine to sustain quality. Every batch is subjected to in-house laboratory testing to ensure compliance with EN standards.



INFRASTRUCTURE

The manufacturing unit is spread over an area of 26000 sq.m². The production facility houses state-of-the-art modern manufacturing machineries, imported and completely automated, designed to perform on statutory factors of cost efficiency and accuracy with minimal manual labour and wastage. Environment-friendly and dedicated buildings function exclusively for extrusion and fabrication of windows and doors with a corporate office building on the same premises.



EUROPEAN
STANDARD
UPVC
PROFILES
WINDOWS
AND
DOORS



OPENABLE SERIES

SL NO	REF CODE	PROFILES APPLICATIONS	WT / MTR-KG	NO OF PCS / BUNDLE	SECTIONS
1	AP-60-OF	Case-Outer frame	1.000	4	
2	AP-60-ML	Mullion	1.040	4	
3	AP-60-OPS	Out Opening Sash	1.099	4	
4	AP-60-SGB	Single Glaze Bead	0.287	20	
5	AP-60-DGB	Double Glaze Bead	0.204	20	
6	AP-60-DS	Door Sash	1.400	4	
7	AP-60-LB	Louver Bead	0.271	10	
8	AP-60-LL	Louver Leaf	0.260	20	
9	AP-60-DP	Door Panel-8mm	0.398	10	
10	AP-60-DP	Door Panel-20mm	0.690	10	

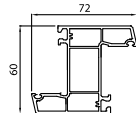
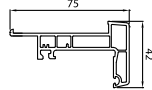
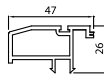
OPENABLE SERIES

SL NO	REF CODE	PROFILES APPLICATIONS	WT / MTR-KG	NO OF PCS / BUNDLE	SECTIONS
11	AP-60-ZML	Z Mullion	1.058	4	
12	AP-60-FLM	Float Mullion	0.730	6	
13	ALP-CDF	Closing Frame for Doors	0.460	12	
14	ALP-C-MOS	Casement Mosquito Sash	0.555	10	

CONNECTING SERIES

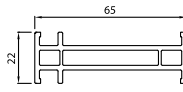
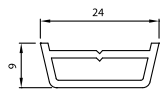
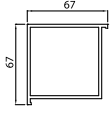
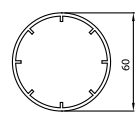
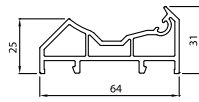
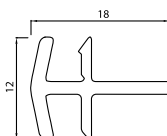
1	AF-CUP1	Frame Connector	0.500	10	
2	AP-GEOB	Georgian Bar	0.155	40	
3	SF-FZJ	Curved Corner	0.780	2	
4	ALP-BP	Baypost	0.668	4	
5	ALP-BPAT	Baypost Adapter	0.533	8	
6	SF-GMT	Three Track Coupler	0.110	40	

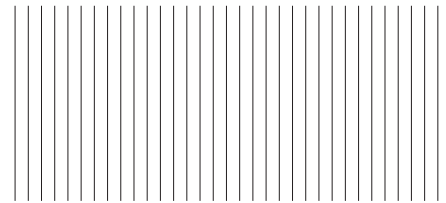

SLIDING SERIES

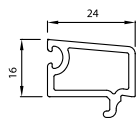
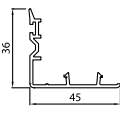
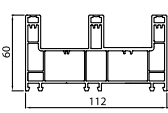
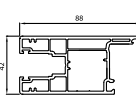
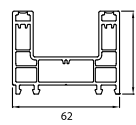
SL NO	REF CODE	PROFILES APPLICATIONS	WT / MTR-KG	NO OF PCS / BUNDLE	SECTIONS
1	AT-60-SF	Two Track Sliding Frame-60mm	1.145	4	
2	AT-95-MQF	Sliding Mosquito Frame	1.542	4	
3	AT-95-SS	Sliding Sash	0.930	6	
4	AT-95-SSGB	Sliding Single Bead	0.229	20	
5	AT-95-WS-IL	Window Sash Interlock	0.224	20	
6	AT-112-SF	Three Track Sliding Frame	1.785	2	
7	AT-88-SS	Sliding Door Sash	1.264	6	
8	AT-95-DS-IL	Door Sash Interlock	0.270	20	
9	AT-60-SF-48	Two Track Sliding Frame-48mm	1.045	4	
10	AT-48-MQF	Sliding Mosquito Frame-48mm	1.245	4	
11	AT-95-SS-57	Sliding Sash 57	0.780	6	

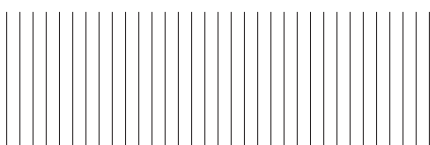

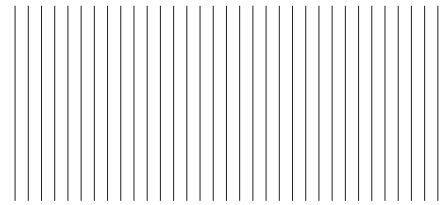

SLIDING SERIES

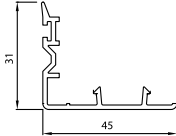
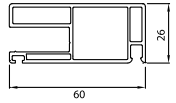
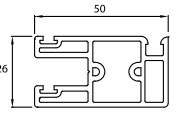
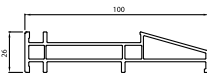
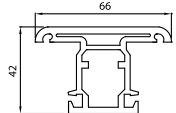
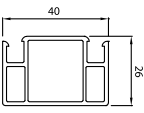
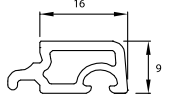
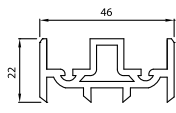
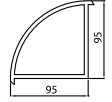
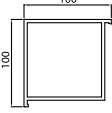
SL NO	REF CODE	PROFILES APPLICATIONS	WT / MTR-KG	NO OF PCS / BUNDLE	SECTIONS
12	AT-57-WS-IL	Window Sash Interlock (Eco)	0.227	20	
13	AT-60-MQS	Mosquito Sash	0.632	10	
14	AT-50-MQS	Mosquito Sash	0.575	10	
15	AP-MQF-CUP	Mosquito Frame Coupler	0.732	10	
16	AT-95-SZT	Sliding Mullion	0.768	6	
17	AP-50-MSM	Mosquito Sash Mullion	0.412	10	
18	AT-95-SDGB	Sliding Double Bead	0.140	30	
19	AT-95-GM	Sliding in line adapter	0.385	10	
20	MQS-FCC	Mosq-Frame Connector - Curve	1.222	4	
21	MQS-FCS	Mosq-Frame Connector - Square	1.413	4	

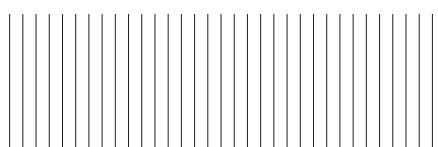

G.I. STEEL REINFORCEMENTS

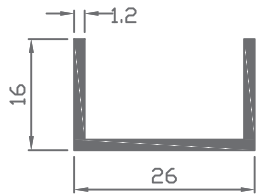
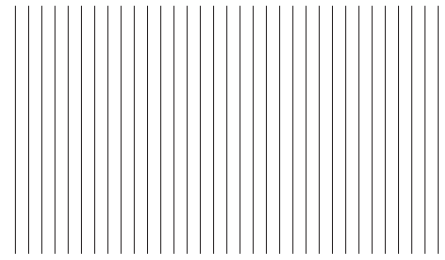

AP-60-OF & AT-60-SF

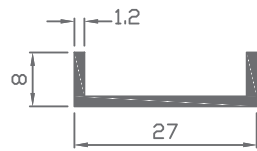

AT-60-SF-48, AT-48-MQF & AT-95-SS

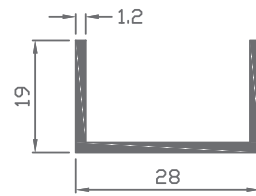

AT-95-MQF & AT-112-SF

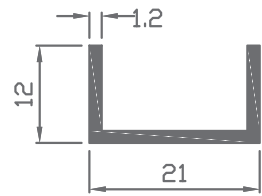

AT-50-MQS

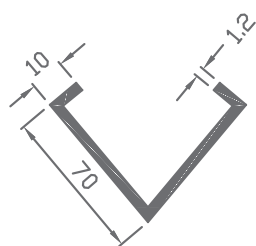

SF-FZJ

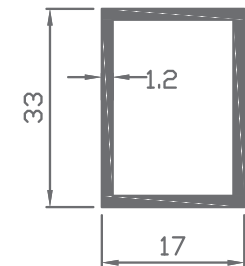

AP-60-ML

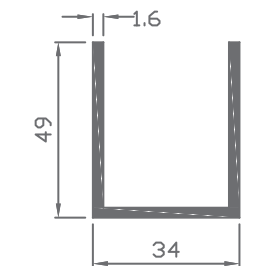

AP-60-DS-3 D- Hinges

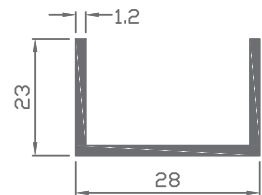

AT-88-SS

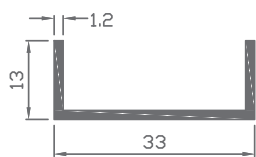

AP-60-OPS-Corner Hinges

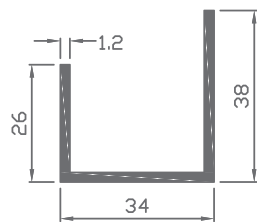

AP-60-DS-Corner Hinges

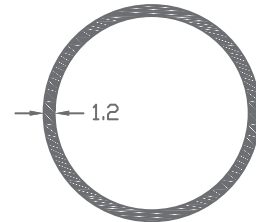

ALP-BP- Outer O-47mm

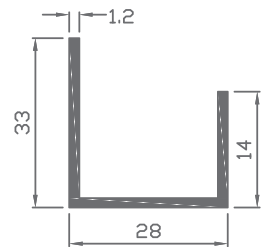

AP-60-OPS-Friction Hinges

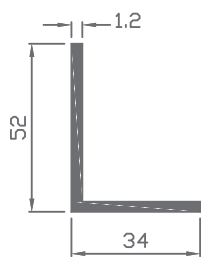

DOOR - SASH - L STEEL - 83 MM

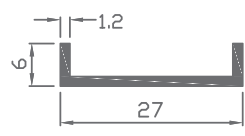

AT-95-SS-57

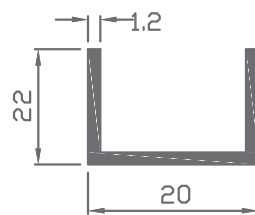

AT-60-MQS

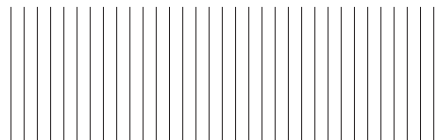

CASEMENT OPENABLE

DOUBLE OPENABLE WINDOW WITH TOP FIXED

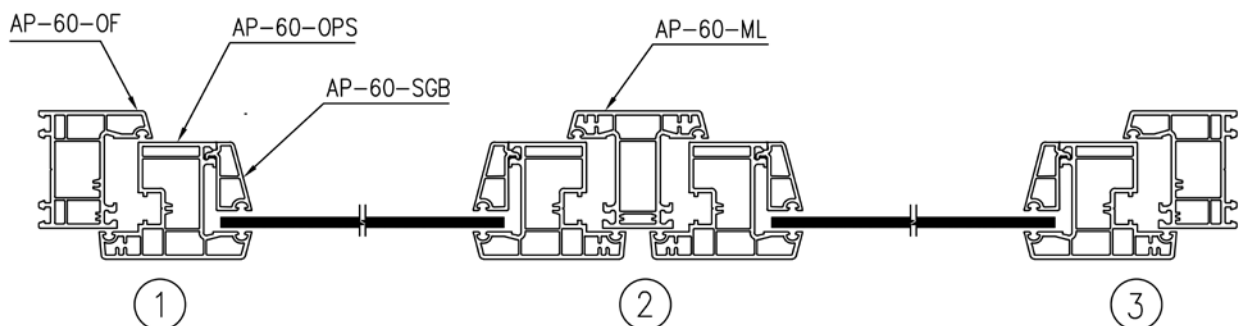
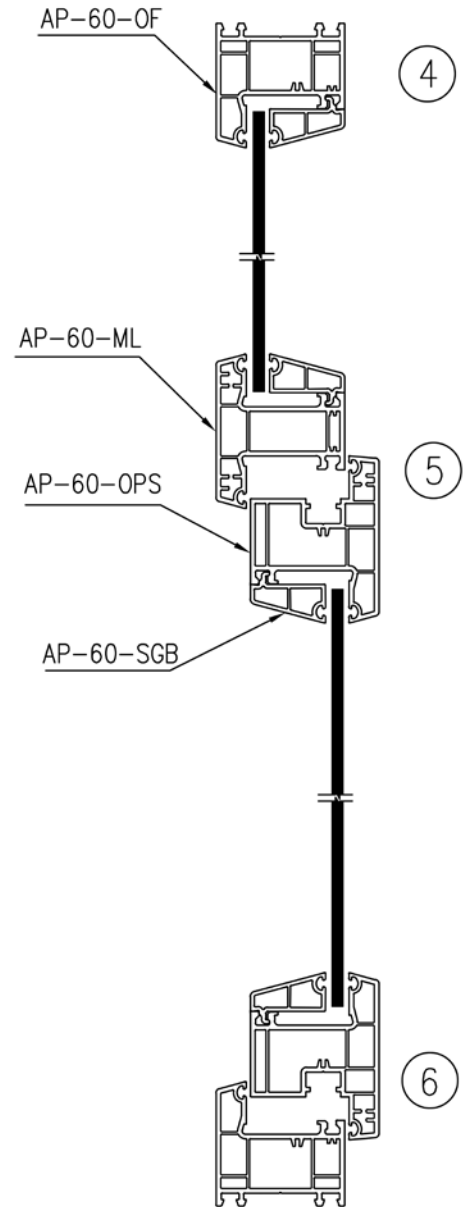
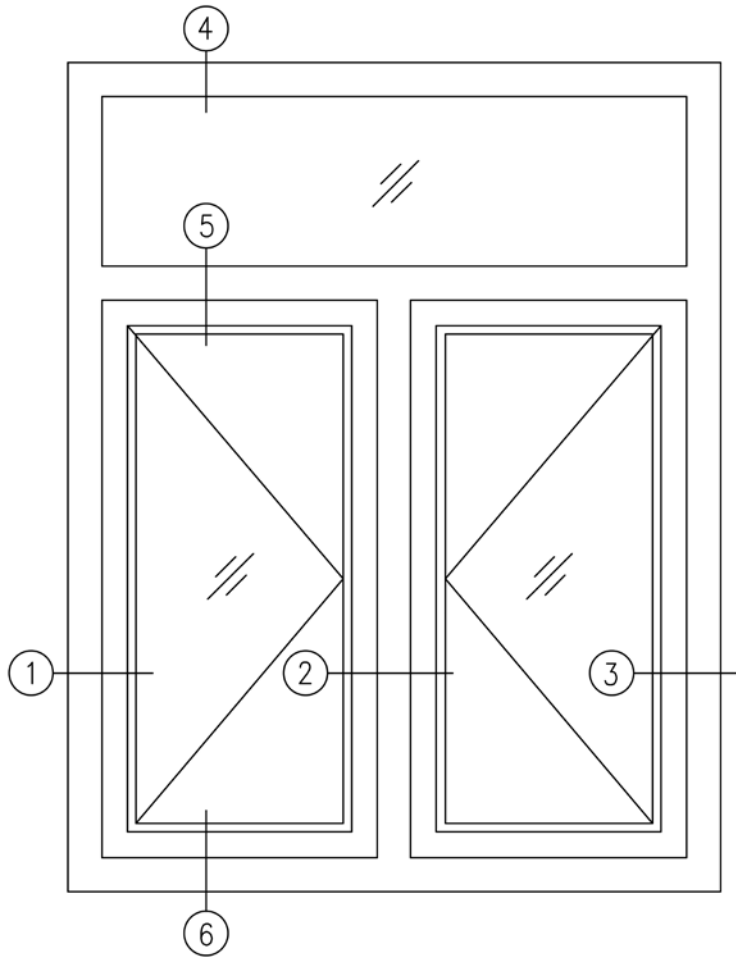

DOOR WITH SIDE WINDOW

OPENABLE DOOR COUPLE WITH SLIDING WINDOW

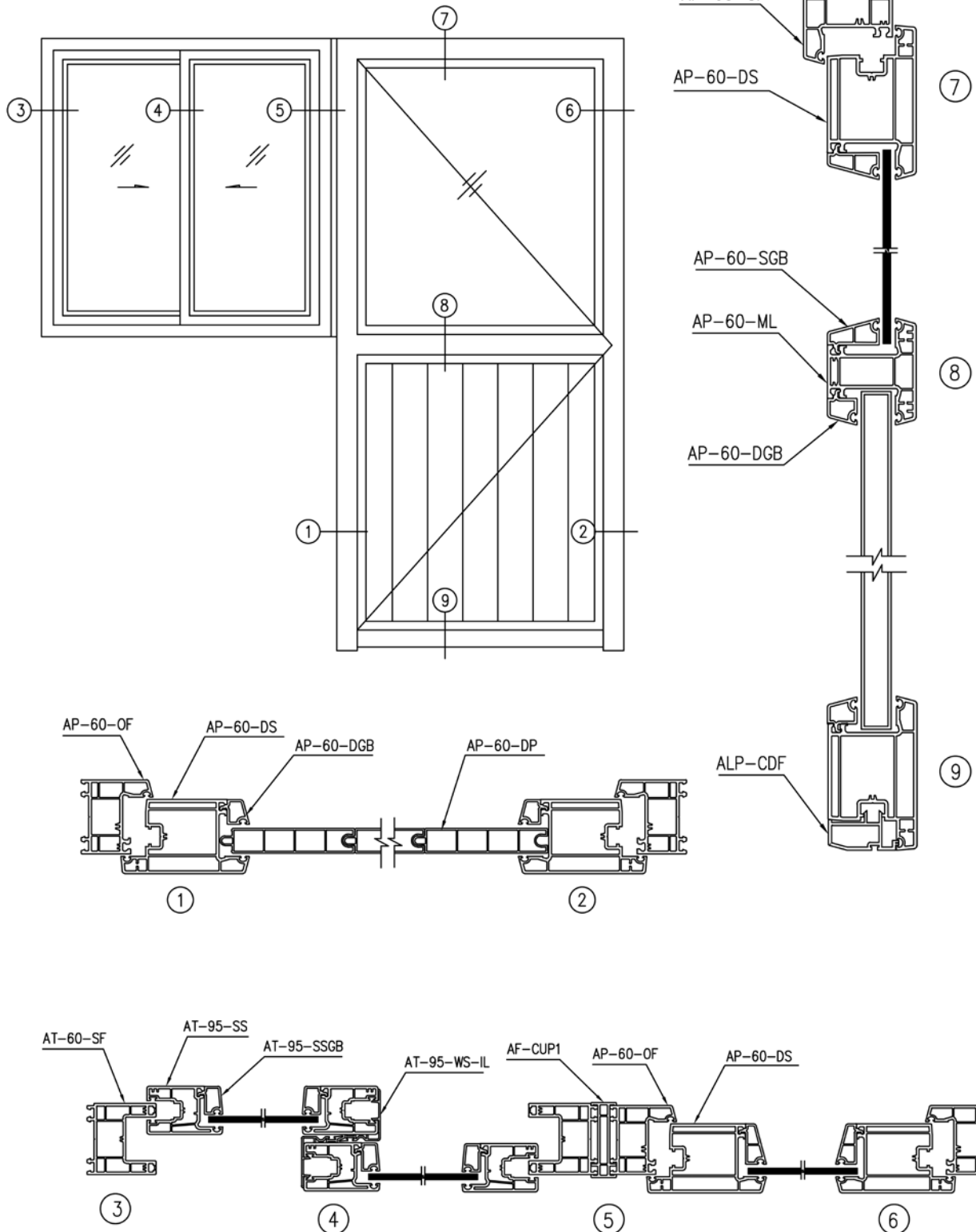

DOUBLE DOOR

DOBLE OPENABLE DOOR WITH TOP FIXED

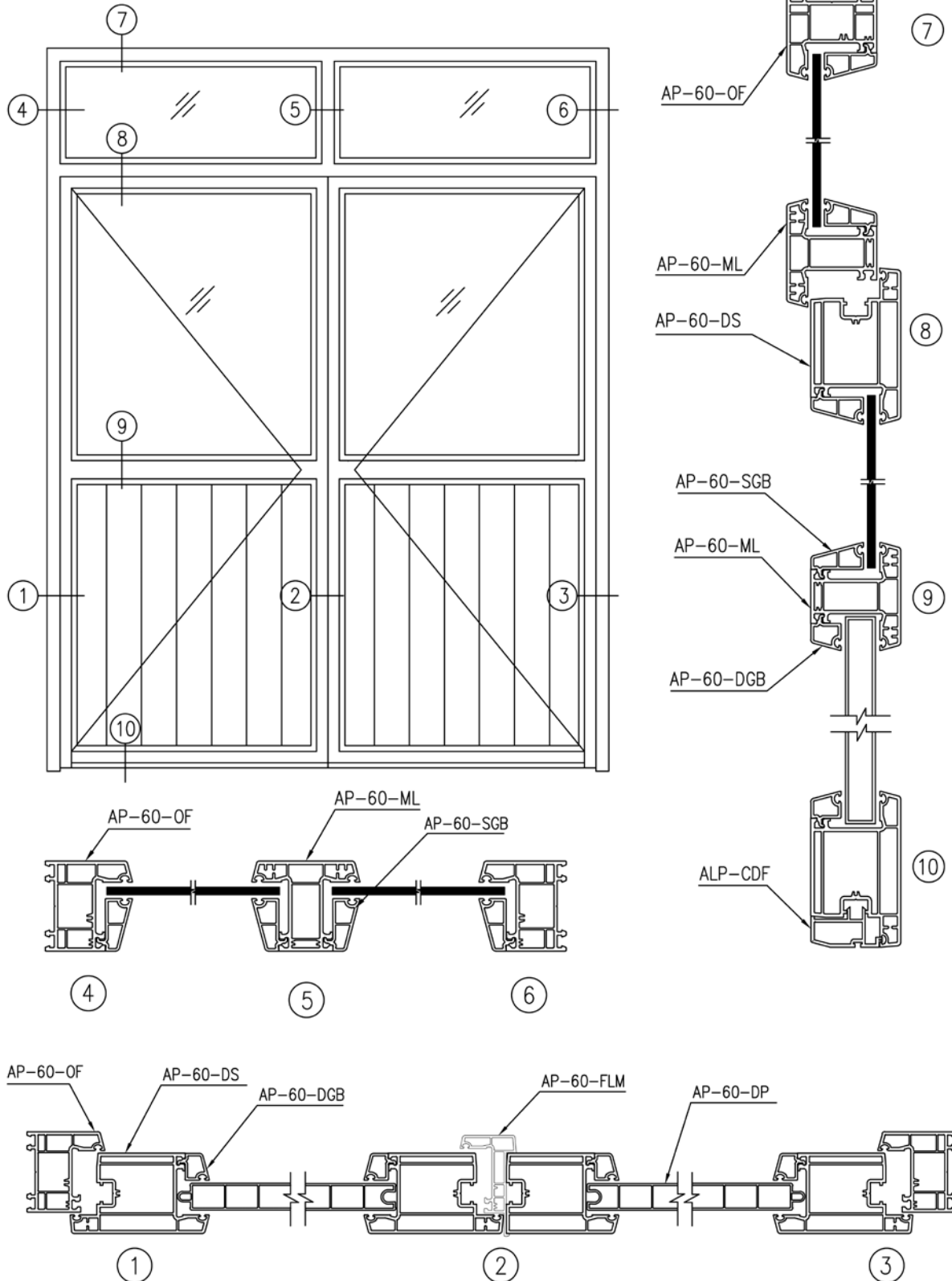

LOUVER BEAD

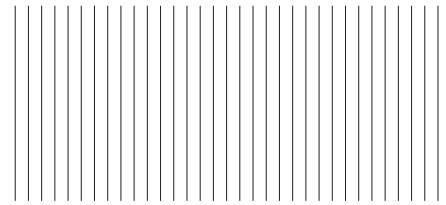

FIXED uPVC LOUVER

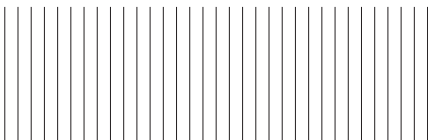
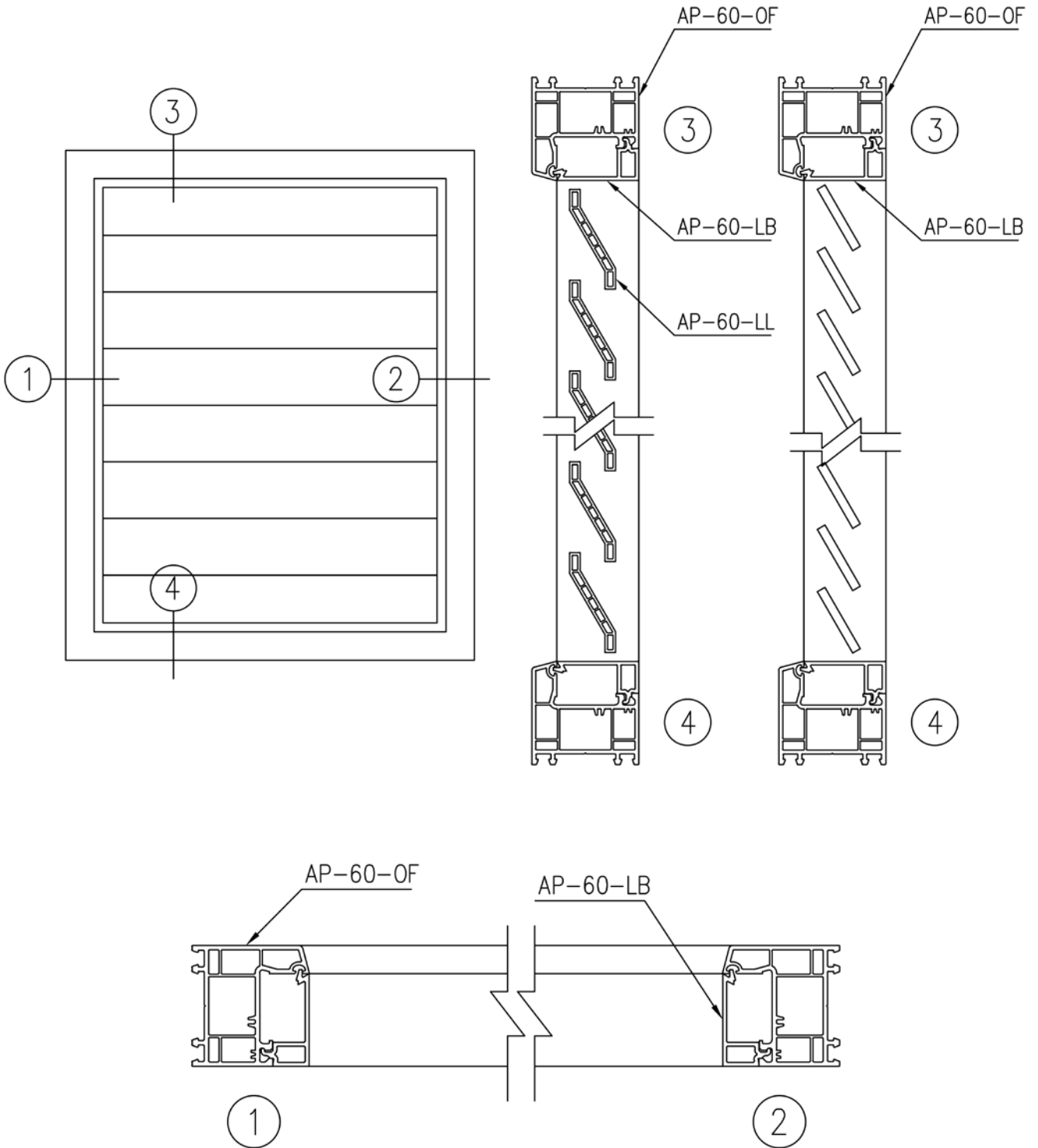

SLIDING DOOR

SLIDING DOOR

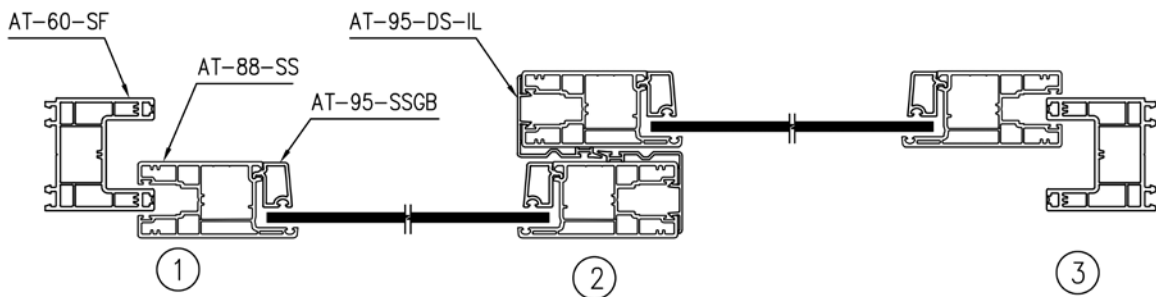
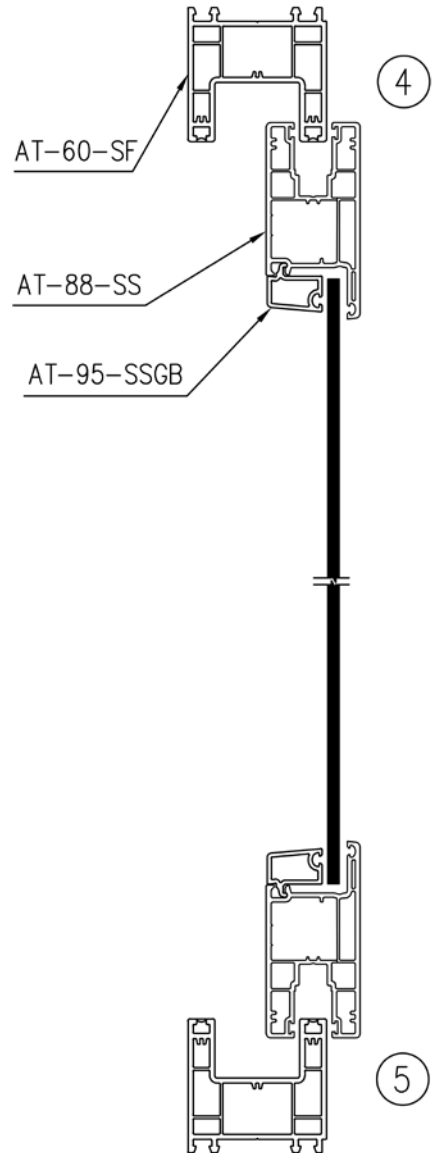
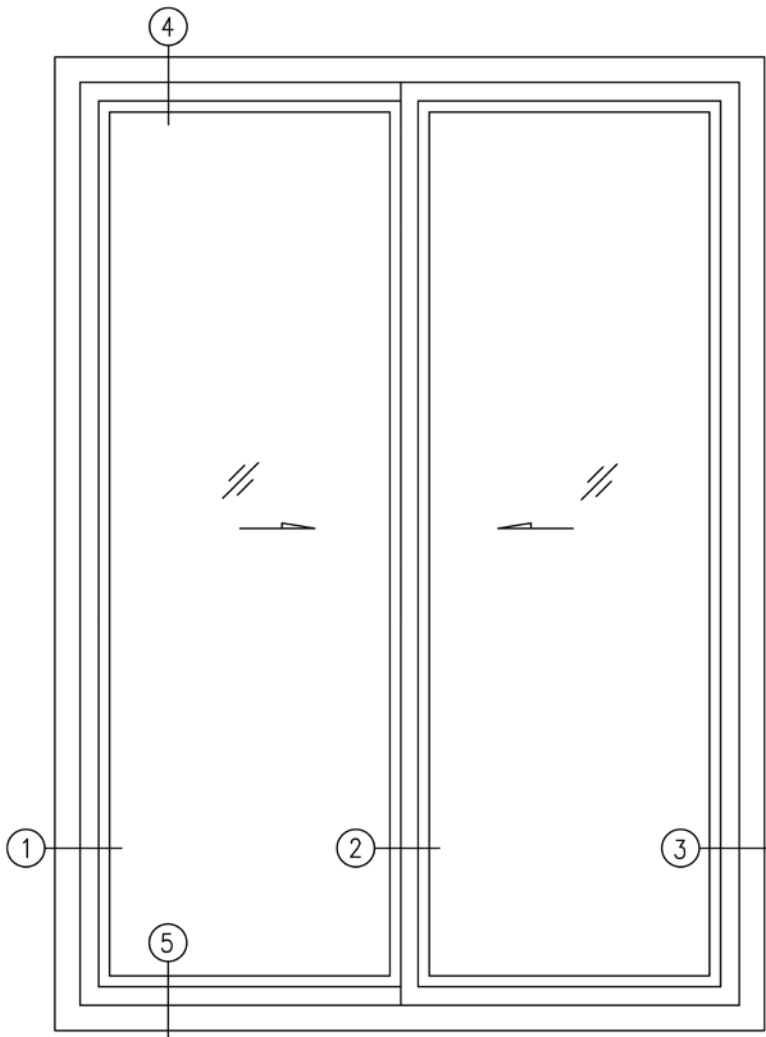

THREE TRACK SLIDING

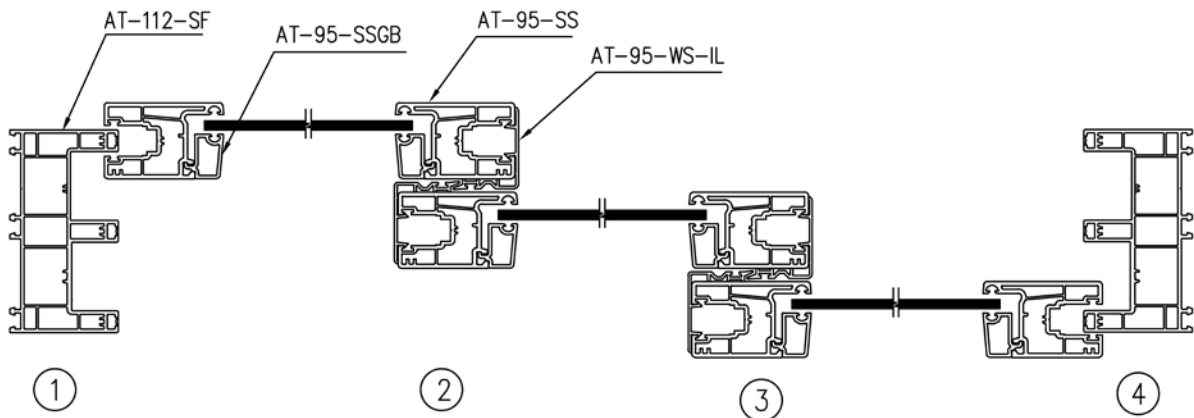
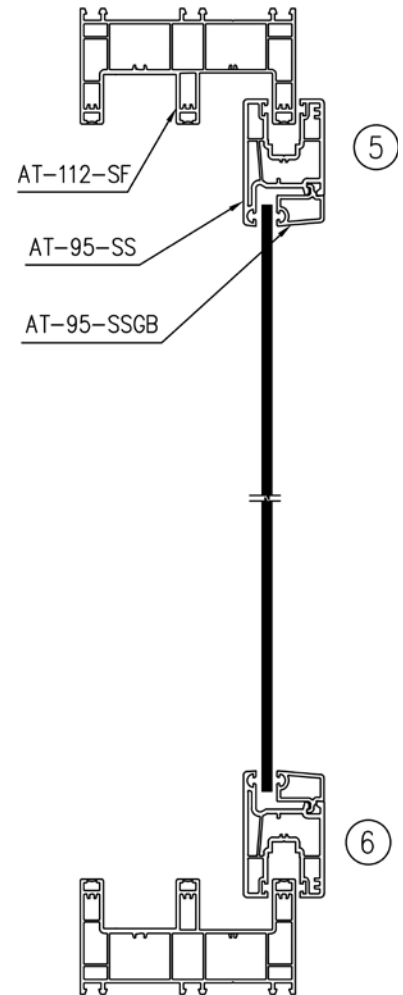
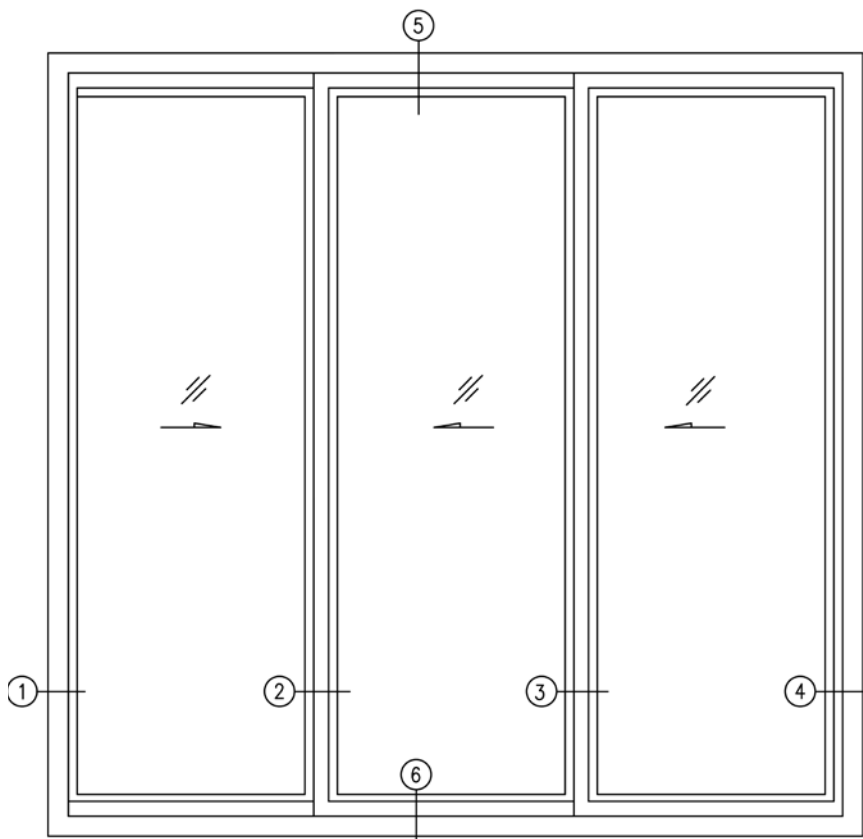

SLIDING DOOR

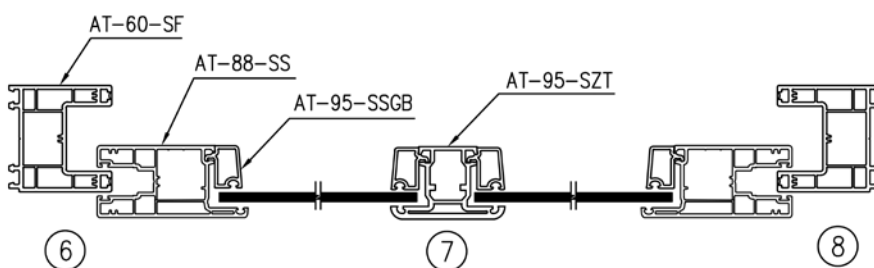
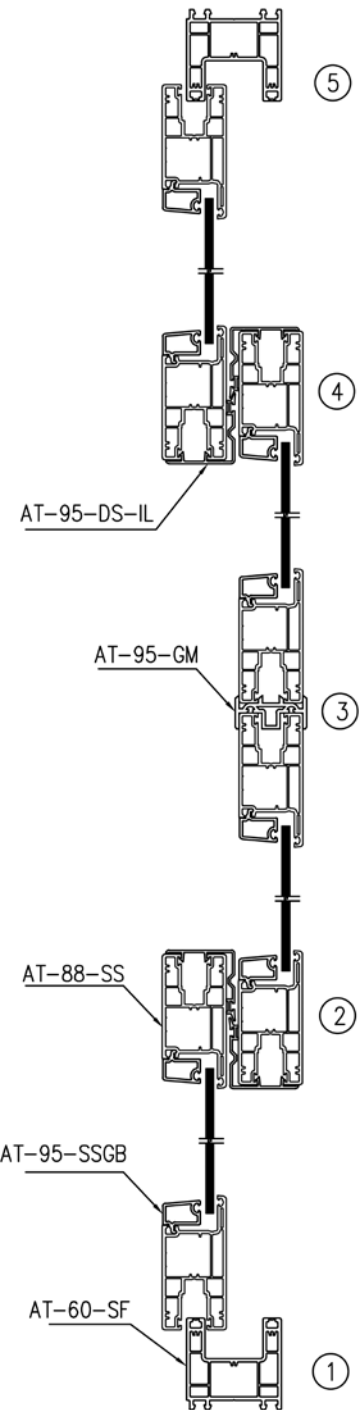
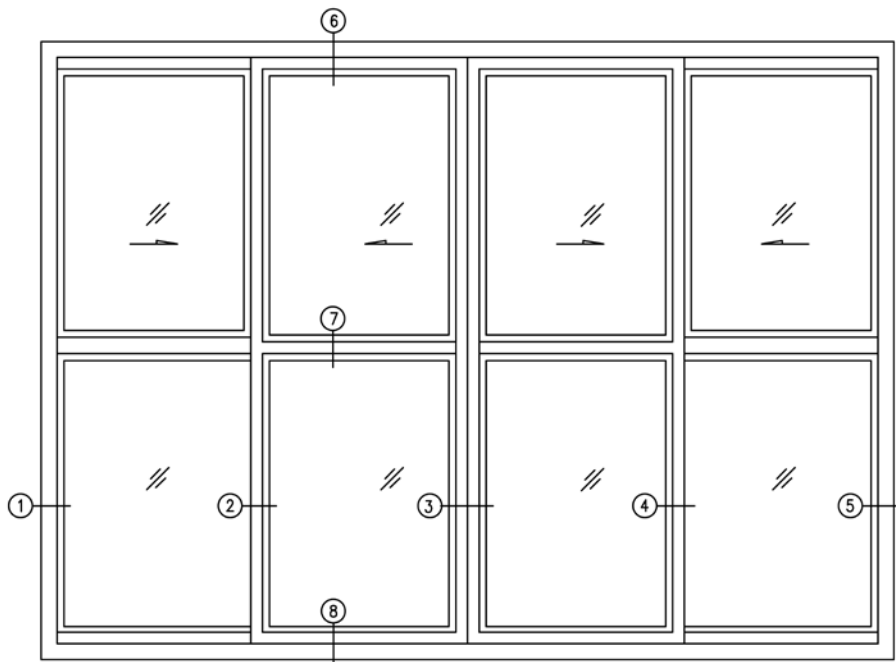

MOSQUITO THREE TRACK SLIDING

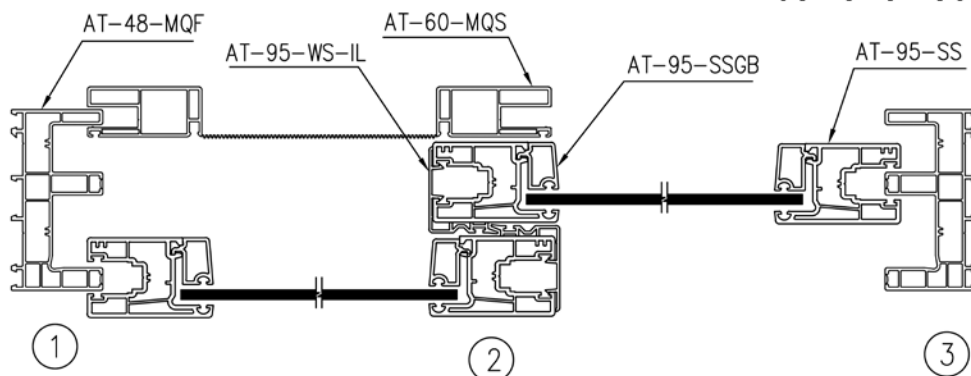
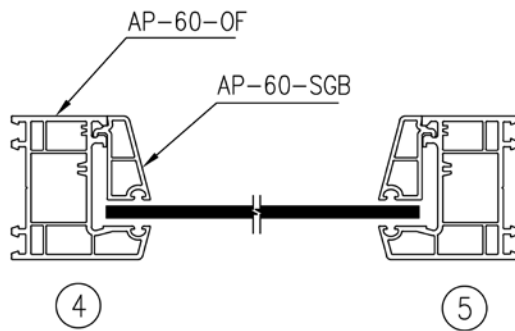
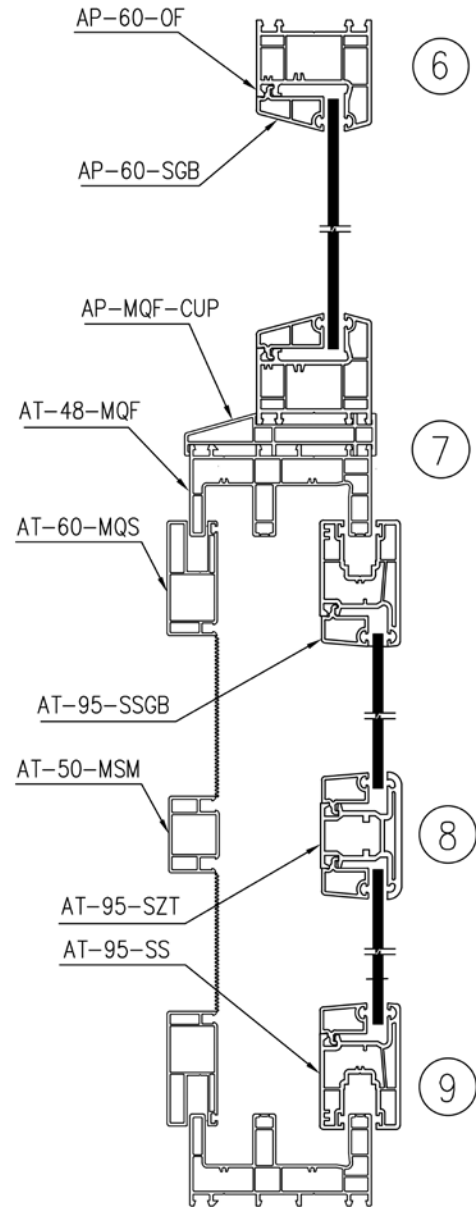
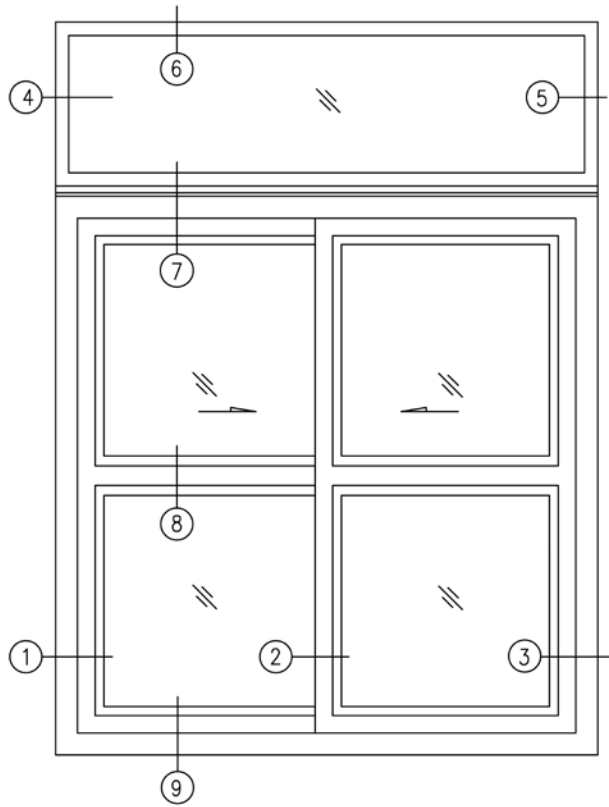

ASSISTING PROFILES

